

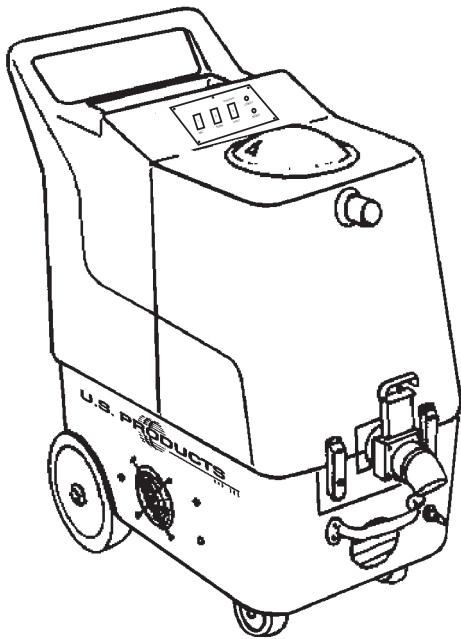

HHP-300 EXTRACTOR 120V



INFORMATION & OPERATING INSTRUCTIONS



**DO NOT OPERATE MACHINE UNTIL YOU HAVE READ
ALL SECTIONS OF THIS INSTRUCTIONS**

IMPROPER USE OF THE MACHINE WILL VOID THE WARRANTY

1. Always use a defoamer when foaming occurs to prevent vacuum motor damage.
2. Keep machine from rain and snow, extremes in temperatures, and store in a heated location. Use the machine indoors. Do not use outdoors.
3. Do not let the pump run dry.
4. Use approved chemicals only. NO SOLVENTS.
5. Wear gloves or use rags when removing quick disconnects to prevent burns.
6. Never use water above 130° F/54° C in the solution tank.

IMPORTANT SAFETY INSTRUCTIONS

This machine is only suitable for commercial use, for example in hotels, schools, hospitals, factories, shops and offices other than normal residential housekeeping purposes.

When using any electrical appliance, basic precautions should always be followed, including the following:

NOTE: Read all instructions before using this machine.

WARNING!

To reduce the risk of fire, electric shock, or injury:

- Do not leave the machine unattended when it is plugged in. Unplug the unit from the outlet when not in use and before servicing.
- To avoid electric shock, do not expose to rain or snow. Store, and use, indoors.
- Do not allow to be used as a toy. Close attention is necessary when used near children.
- Use only as described in this manual. Use only the manufacturer's recommended attachments.
- Never add water over 130° F/54° C to the solution tank.
- Do not use with damaged cord or plug. If the machine is not working as it should, has been dropped, damaged, left outdoors or dropped into water, return it to a service center.
- Do not pull by the cord, use the cord as a handle, close a door on the cord, or pull the cord around sharp edges or corners. Do not run the machine over the cord. Keep the cord away from heated surfaces. To unplug, grasp the plug, not the cord.
- Do not handle the plug, the cord or the machine with wet hands.
- Extension cords must be 12/3 and no longer than 50 feet. Replace the cord or unplug immediately if the ground prong becomes damaged.
- Do not put any object into openings. Do not use with any opening blocked; keep free of dust, lint, hair, and anything that may reduce air flow.
- Keep loose clothing, hair, fingers, and all parts of body away from openings and moving parts.
- Do not pick up anything that is burning or smoking, such as cigarettes, matches, or hot ashes, or any health endangering dusts. Do not use to pick up flammable or combustible liquids such as gasoline or use in areas where they may be present.
- Turn off all controls before unplugging.
- Use extra care when cleaning on stairs.
- Connect to a properly grounded outlet only.
- Liquid ejected at the spray nozzle could be dangerous as a result of its temperature, pressure, or chemical content.

INSPECTION:

Carefully unpack and inspect your HHP -300 for shipping damage. Each machine is tested and inspected before shipping. Any shipping damage incurred is the responsibility of the carrier. You should notify the carrier immediately if you notice damage to the box or to the machine or parts.

CLEANING SOLUTIONS:

We recommend liquid cleaning chemicals. Powder chemicals may be used, but unless mixed very thoroughly they could cause a build-up in the pump, lines, heat exchanger and/or quick disconnects. Any problem caused by a chemical build-up is not covered by warranty. Use a neutral cleaner with a pH between 5 and 10 to avoid premature wear of the pump, seals, and/or other components. Damage caused by the use of strong chemicals is not covered by the warranty.

MAINTENANCE:

For optimum performance flush the machine with clear water at the end of each working day. Once a month, minimum, run a flushing compound through the machine to break up any mineral or chemical build-up that may have formed. The vacuum motor, pump motor, and the pump do not require any scheduled maintenance; however, the motors may require replacement brushes after 1000 - 1500 hours, and the pump and bypass valve may require rebuild kits after 1000 - 1500 hours, typically (refer to machine part list for numbers). Clean the body with an all-purpose detergent, and protect it with an automobile interior polish. Lubricate the wheels, castors, and quick disconnects with an all purpose silicone spray.

PARTS AND SERVICE:

Repairs, when required, should be performed by your authorized distributor who maintains an inventory of original replacement parts and accessories. Call the distributor from whom you purchased this machine if you need parts and service. Be sure to specify the machine model. Have your serial number handy.

Serial Number: _____

Model: HHP-300

Purchase Date: _____

Write the name and phone number of our distributor:

(and be sure to register your purchase to activate your warranty)

SWITCH PLATE:

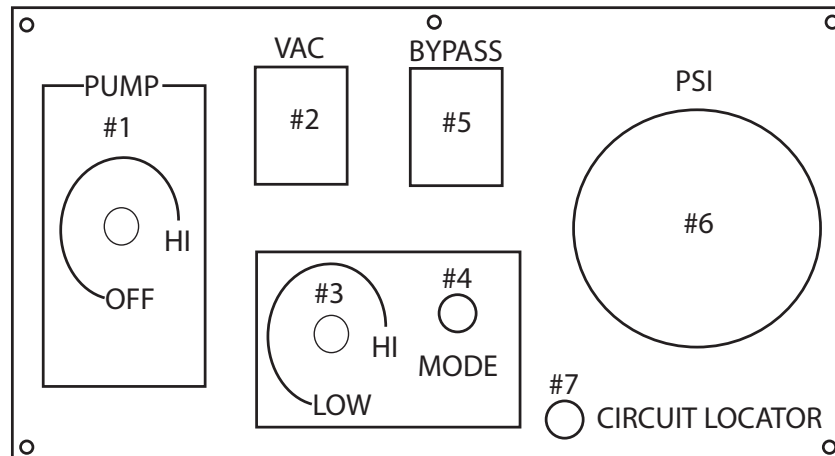

PUMP DIAL (1):

This dial controls motor speed and pump pressure. Adjust the dial clockwise to increase pressure and counterclockwise to decrease pressure or turn off pump. The pump runs off of cord #1.

VACUUM SWITCH (2):

This switch will illuminate when the vacuum motor is on. The vacuum motor runs off of cord #1.

HEAT CONTROL (3):

This dial controls the water temperature. Turn it clockwise to increase water temperature and counterclockwise to decrease temperature. The heater will operate only if the circuit locator light (#7) or the bypass switch (#5) is on.

HEAT MODE LIGHT (4):

This light will only illuminate when the heater is heating and will turn off when it reaches operating temperature. During normal operation, the "MODE" light will be on most of the time.

BYPASS SWITCH (5):

The bypass switch will illuminate when it is activated and will completely bypass the circuit locator system. Use this system only when the circuit locator light will not turn on and you know each cord is on a separate circuit.

CAUTION: WHEN THE BYPASS SWITCH IS ON, THE CIRCUIT BREAKER CAN TRIP IF BOTH CORDS ARE ON THE SAME CIRCUIT AND THE BYPASS SWITCH IS TURNED ON.

PRESSURE GAUGE (6):

Indicates pump spraying pressure (the air bubble inside the gauge is normal). Do not operate the machine if the with the needle goes above 325 psi.

CIRCUIT LOCATOR (7):

When this light is on, it indicates that cord #2 (Identified by the red "H" on the back of the extractor.) is on a separate line from cord #1. Cord #2 supplies voltage to the heater allowing it to heat to the temperature range indicated by the Heat Control dial (#3) on the switch plate.

SET-UP and OPERATION:

Fill the holding tank with clear water and the detergent of your choice. Mix well. Although this machine is designed to supply instant hot water, the addition of warm water to the holding tank would increase heater efficiency. Never use water above 130° F/54° C in the solution tank.

1. Plug in cord #1. (This cord runs the pump and vacuum). Attach the priming hose to the machine and place the open end into the tank (see Fig. #1)
2. Turn on the pump (turn pump pressure dial all the way clockwise) and let it run until the pump is fully primed (approximately 30 seconds to 1 minute - older pumps may take longer). Turn off the pump and disconnect the priming hose. Attach the cleaning hose and tool.
3. Turn on the pump and spray through the cleaning tool for a few seconds to fill the lines with solution.
4. Plug in cord #2 (indicated by the red "H" on the back of the machine). IF THE GREEN LIGHT ILLUMINATES, THE HEAT EXCHANGER WILL TURN ON AUTOMATICALLY (SEE NOTE BELOW). Wait until the red mode light goes out (approximately 2 minutes) for the heat exchanger to reach operating temperature. You may now begin cleaning. NOTE: During normal operation, the red light will be on most of the time.

NOTE: If the green circuit indicator light does not illuminate when cord #2 is plugged in, then both cords are on the same circuit. Try other outlets until the light comes on. See bypass switch section (below) if you are unable to get a green light.

ELECTRIC CIRCUIT LOCATOR:

This unique, patented "smart system," operated by a solid state circuit, will inform the operator when the two cords are plugged into separate lines by illuminating the green, indicator light. This helps prevent tripping circuit breakers.

BYPASS SWITCH:

The bypass switch (#5) completely bypasses the circuit locator system. Use this feature when you cannot get the green Locator light (#7) to come on and you believe that the two cords are on separate circuits.

CAUTION: If the bypass switch is on when the two cords are plugged into the same circuit, the breaker may trip.

AUTO VACUUM SHUTOFF:

When the recovery tank is full, the float system will shut off the vacuum motor and prevent the machine from overflowing. The float may not work in foam. Always use a defoamer to prevent overflow. Once the vacuum motor shuts off, the vac switch (#2) must be turned off, the recovery tank emptied, and then the vacuum switch turned back on (up position) to get the vacuum motor started again.

CAUTION: Always make sure the float is clean and travels freely before turning on the machine. A float that is stuck will cause the vacuum motor to suck in water, resulting in vac motor damage.

PUMP PRESSURE:

Make sure the cleaning tool is spraying when adjusting the pressure, otherwise the pressure reading will be inaccurate.

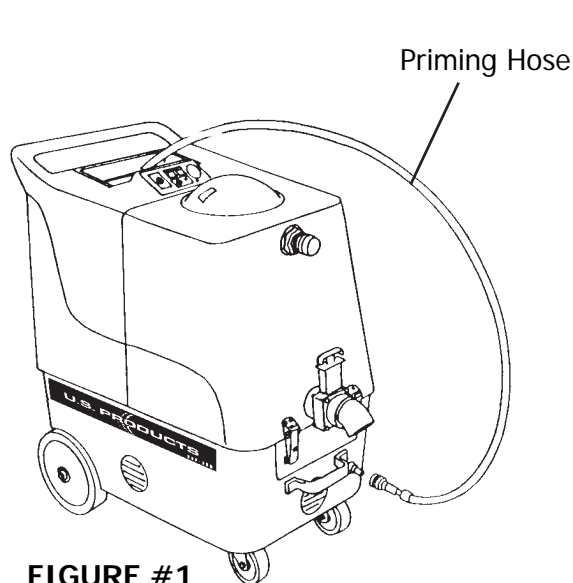

FIGURE #1

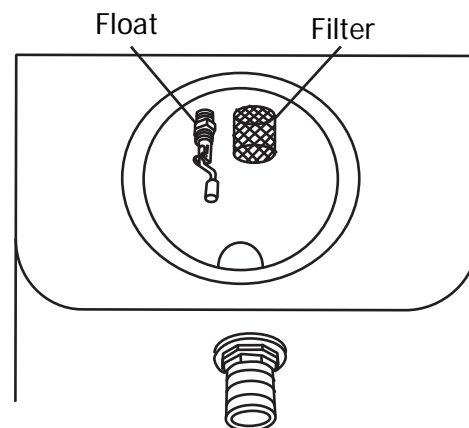
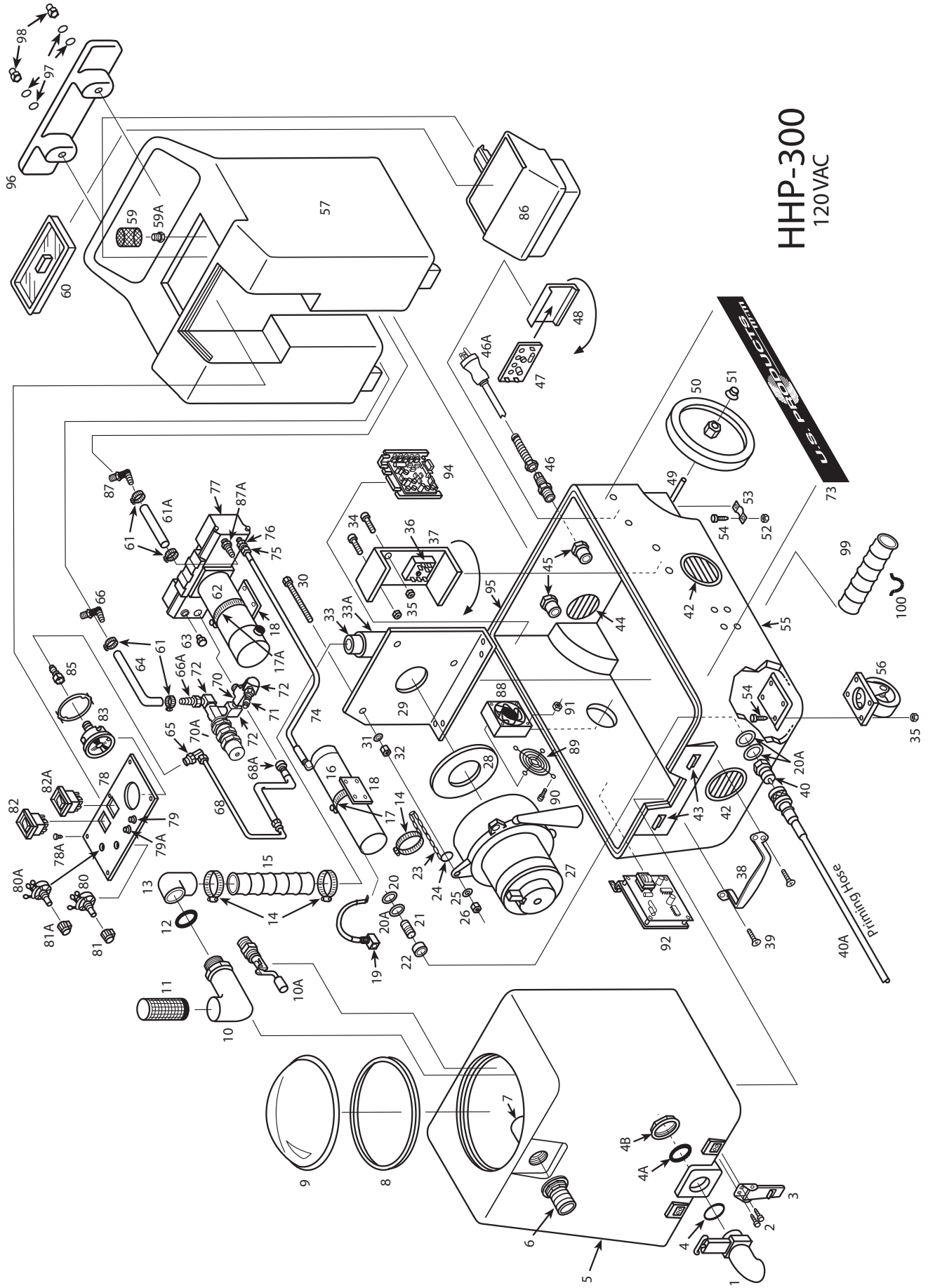

FIGURE #2: Shows the float and inlet filter. Each time the recovery tank is emptied, the float should be checked for hair and dirt that may effect float operation (float must travel freely). The filter is removable and must be kept clean.

HHP-300

120VAC



HHP-300 120V PARTS LIST

ITEM PART# DESCRIPTION

#1	FP231	Drain Gate
#2	21C	Screw, Button Head, 10-32 x 5/8"
#3	908	Latch
#4	187	O-Ring, Small
#4A	187B	Washer, rubber
#4B	185	Nut, 1-1/2"
#5	V-1	Vacuum Tank, HHP
#6	907	Hose Barb, 1-1/2"
#7	922	PVC Elbow, 1-1/2"
#8	2009	Gasket (Vacuum Dome)
#9	FP201	Vacuum Dome
#10	FP216	PVC Elbow Assembly
#10A	2026	Float, Vacuum Shut-Off, Electronic
#11	929	Filter, Vacuum, Inlet
#12	187	Washer, rubber
#13	922	PVC Elbow, 1-1/2"
#14	156	Hose Clamp, (Size 28)
#15	FP171	Hose, Vacuum, Rubber, 20"
#16	FP159	Heat Exchanger, Complete
#17	198	Hose Clamp (Size 48)
#18	455	Heat Exchanger Mount
#19	FP164	Hose Assy, Braided, for Heat Exchanger, Outlet
#20	31	Washer, Brass
#20A	115	Washer, Fiber
#21	92A	Nipple, S/S, 1/4", p.t.
#22	116A	Bushing, Fiber
#23	934	Chain, 9.5"
#24	194	Split Ring
#25	15	Washer, 5/16"
#26	7	Lock Nut, 5/16 x 4"
#27	FP323	Vacuum Motor, 3-stage w/Connectors
#28	959	Gasket (Vacuum Motor)
#29	926	Vacuum Manifold
#30	179	Bolt, 5/16" X 4"
#31	34	Washer, 5/16"
#32	320AB	Nut, 5/16"
#33	935	Sleeve, PVC, 3"
#33A	921	Elbow, PVC
#34	4	Bolt, 3/4" X 1"
#35	8	Lock Nut, 1/4-20
#36	see Misc.	Thermistor Control with Potentiometer**
#37	918	Heat Sink Plate
#38	2010A	Handle, Chrome
#39	193	Screw, Flathead, 1/4"-20 x 3/4"
#40	45	Quick Disconnect, Male, 1/4 p.t.
#40A	SYP1	Priming Hose Assy. 4 1/2 ft.
#42	928	Louver, 3" (includes screws)
#43	909A	Latch Strike, for Latch, S/S
#44	459	Louver, 2-1/2" (includes screws)
#45	937	Reducer, PVC
#46	184	Cord Retainer
#46A	495A	Power Cord, 25', Yellow
#47	923B	Circuit Board, Dual Cord Sensor
#48	931	Mounting Track, Circuit Board
#49	910-15.56	Axle rod
#50	2003	Wheel, 8"
#51	27A	Axle Cap
#52	28	Lock Nut, 1/4-20
#53	180	Axle Bracket
#54	5	Bolt, 1/4" X 3/4"
#55	FP437	Base, HHP
#56	905	Caster, Swivel, 4"
#57	FP379	Holding Tank, HHP
#59	207A	Filter, 40 Mesh, S/S

ITEM PART# DESCRIPTION

#59A	92B	Nipple, PVC, 1/2" n.p.t.
#60	901	Lid, Holding Tank
#61	166	Hose Clamp
#61A	FP170	Hose, 1/2" x 18", Pump Inlet
#62	948B	Motor (300 PSI Pump), DC Volt
#63	211	Plug, Brass, 1/4 p.t.
#64	FP169	Hose, 3/8", Pump Bypass
#65	220	Quick Disconnect, Open, 1/4" p.t.
#66	1083	Hose Barb, 90 Degree, 3/8" x 1/4"
#66A	164	Hose Barb, 3/8" Hose x 1/4 p.t., Brass
#68	FP168	Hose, Pump to Gauge, Complete
#70	168	"T", Brass
#70A	945	Bypass Valve, Complete
#71	221	Quick Disconnect, Male, Open, 1/4 m.p.t.
#72	91	Elbow, Brass, 1/4 p.t.
#73	942	Label, HHP-300
#74	224	Hose, Pump to Heater, 8"
#75	222	Quick Disconnect, Female, Open, 1/8 p.t.
#76	223	Quick Disconnect, Male, Open, 1/8 p.t.
#77	FP167	Pump, 300 PSI, NO motor
#78	943	Switch Plate (No Switches)
#78A	28	Screw, #4 x 3/8"
#79	78	Light, Green, Small
#79A	78B	Light, Red, Small
#80	255	Potentiometer, Heat Control
#80A	FP200C	Potentiometer, w/Cable, Pump Control
#81	248	Knob, Red (Heat)
#81A	249	Knob, Blue (Pump)
#82	FP578	Switch, Rocker, Vacuum
#82A	FP578	Switch, Rocker, Bypass
#83	951A	Gauge, PSI Pressure, 2-1/2"
#85	219	Quick Disconnect, Male, Open, 1/4" p.t.
#86	FP204	Funnel, Black
#87	1113	Hose Barb, 90 Degrees, 1/2" X 1/2"
#87A	165	Hose Barb, 1/4" x 1/2", Nylon
#88	2014	Fan, Cooling
#89	2015	Guard, Fan
#90	2B1	Screw, 6/32 X 2"-1/4"
#91	16	Lock Nut, 6-32"
#92	FP225	Vacuum Board, Complete
#94	FP314	Motor Speed Board, w/Resistor, (Pump)
#95	FP228A	Gasket, Base
#96	CWBLK	Cord Wrap, Black
#97	203	Washer, Nylon
#98	260	Nut, Acorn, 3/8"
#99	430	Hose, Exhaust, 2" x 12"
#100	928A	Strap for exhaust hose

*MISCELLANEOUS ASSEMBLIES/PARTS

291	Bypass Rebuild Kit
229	Valve/O-Ring Kit, Pump
250	Piston/Seal Kit, Pump
242	Brush for Pump Motor (order 2)
FP212	Pump & Motor, Complete
950A	Bearing/Cam Assembly (for Pump)
**FP194C	Heat repair kit with Potentiometer, Probe, Thermal Cutout & Circuit Board
**FP194E	Heat repair kit with potentiometer, probe, cutout
FP2008	Vacuum Dome w/Gasket

(NOTE: Items in kits not sold separately.)

TROUBLE SHOOTING:

IF THIS OCCURS

CHECK THIS

NO SPRAY	Solution tank is empty. Clogged spray tip. Pump not running or not primed. Valve on wand not operating.
PUMP DOES NOT RUN	Check the brushes in the pump motor. Replace if necessary. No power to pump. Test the Motor Speed Control Circuit Board and potentiometer.
LOW SUCTION	Debris is plugging cleaning tool or vacuum hose. Drain gate is not completely closed, or seals are damaged. Vacuum dome is not seated or is damaged.
NO SUCTION	No power to motor. Test the Electronic Float. Test the switch. Test the vacuum motor. Test the Vacuum Circuit Board.
LOW HEAT	Spraying too long. Try spraying for 12-15 seconds per cycle. Heat exchanger needs to be flushed. Wrong tool being used. Too much water passing through. Longer hose or larger diameter hose, than standard
NO HEAT	Heat is not turned on. Either the green light must be on or the bypass switch must be turned on. No power in the wall outlet - check to see if the breaker has tripped. No power to the bypass switch - check wiring for 'opens.' No power out of bypass switch, follow troubleshooting steps to isolate the problem. Call your distributor for additional help.

SPECIFICATIONS:

Rotomolded Body:	Lifetime Warranty
Vacuum:	7.2", 3-stage
VAC Shutoff:	Electronic
Pump:	Positive displacement, fully adjustable 0-300 psi
Waterlift:	140"
Heat:	Adjustable to 212° F
Heater:	2000 Watts
Wand:	Stainless steel, double bend, twin tip
Weight:	92 lbs.
Dimensions:	26.5H x 18W x 28.75L (inches)



208-772-0573 • 800-257-7982 • FAX: 208-772-0577

VISIT US AT: <http://www.usproducts.com>