

1609-8636

HYDRO-WELL III

100 GALLON FRESH WATER TANK

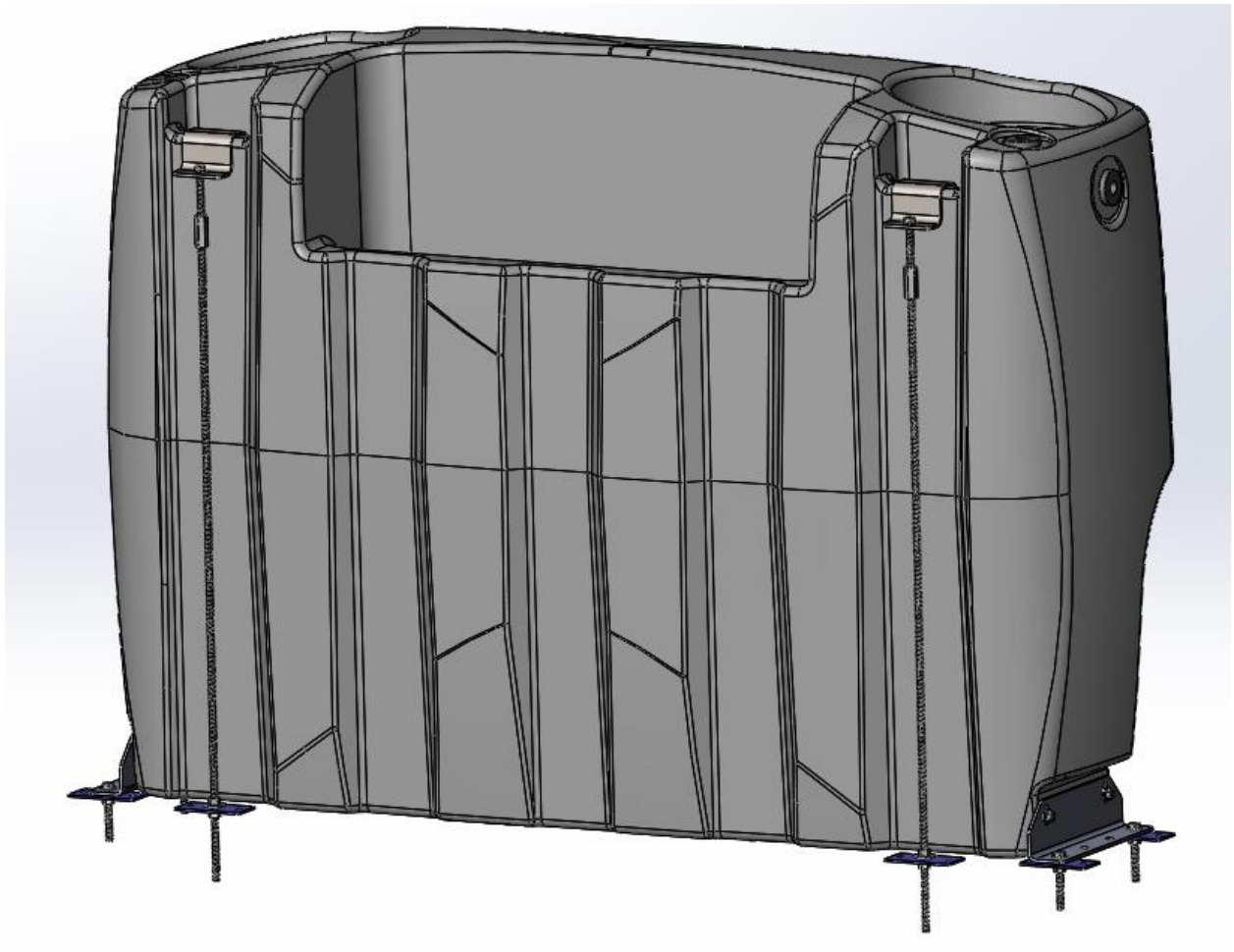

Hydro-Force Manufacturing
4282 South 590 West
Salt Lake City, UT 84123
801-268-2673
801-268-3856 FAX

INTRODUCTION

Congratulations on your purchase of the Hydro-Well III 100 gallon water tank.

Years of experience, engineering, and planning have gone into the design and manufacturing of the Hydro-Well III. We take a great deal of pride in the Hydro-Well III; our goal is no less than your complete satisfaction.

This manual will provide users with the knowledge to properly install the Hydro-Well III.

Any questions pertaining to the operating or servicing of this unit should be directed to your nearest Hydro-Force distributor.

This manual is written specifically for the Hydro-Well III manufactured by:

Hydro-Force Manufacturing
4282 South 590 West
Salt Lake City, UT 84123
801-268-2673
801-268-3856 FAX

Information in this manual is subject to change without notice and does not represent a commitment on the part of Hydro-Force, its parent or affiliated companies.

CAUTION:

While the Hydro-Well III is designed for use with cold water, hot water from residential or commercial building water heaters may be safely used if the incoming water temperature is below 150°F or 65°C.

However, if you are using hot water, make sure the water temperature in the tank does not exceed the temperature rating of your pump. Check with the pump manufacturer or your distributor for information on the temperature rating of your pump.

Heated by-pass water from a truck mounted cleaner must not be circulated back to the Hydro-Well III.

High incoming water supply pressure may flow through closed Float Valve. Observe tank during filling and turn off water as soon as tank is full. In some areas an inline pressure regulator may be required to prevent the Hydro-Well III from overflowing.

The Hydro-Well III should only be filled while the vehicle is parked on a level area. Filling the tank while parked on an incline may prevent the Water Control Valve or overflow ports from operating properly. This can cause the tank to overflow inside the van or over-pressurize and damage the tank.

SPECIFICATIONS

Model 1609-8636 Hydro-Well III:

Width: 61 inches

Depth: 22 inches

Height: 42 inches

Weight (Empty): approximately 115lbs.

Tank Construction: LLDPE

Water Capacity: 100 gallons

Vehicle Requirements & Preparation

The vehicle must have a cargo capacity to handle the weight of the Hydro-Well III as well as the weight of more than 100 gallons of water. A Hydro-Well III, when full of water, can weight more than 1000lbs. For this reason we recommend that the Hydro-Well III only be installed in full size 3/4 ton or 1 ton vans or trucks.

The Hydro-Well III is designed to be mounted almost anywhere in the vehicle. It can be mounted against the wall on either side, over the wheel well or mounted away from the wall across the middle of the van.

The Hydro Well III can be mounted directly to the van floor. Depending on the placement of the floor mount brackets in relation to the van floor ribs, some shimming may be required to keep the brackets flat when bolting the tank directly to the van floor.

The felt padding on the back of the vehicles factory floor mat can absorb & hold water causing accelerated rusting of the van floor and allowing growth of mold and mildew. The removal of the felt backing before installing the Hydro-Well III is recommended.

The most stable installations are achieved when the Hydro-Well III is installed on top of a flat smooth floor. This can be accomplished by installing a floor made of 1/2" or 3/4" exterior grade or marine grade plywood in the van. The factory floor mat (with padding removed) can be re-installed on top of the plywood floor or indoor/outdoor carpeting can be installed on top of the floor if desired.

Position the tank to leave adequate clearance to properly mount the tank and so the tank does not restrict access to other equipment. Be sure to maintain safe distances between the tank and any moving parts and heat sources which could damage the tank.

When selecting the tank mounting location, set the tank in place and check under the van for obstructions which can make it difficult or impossible to drill holes, place bolt & secure the nuts to hold the tank in place securely. Move the tank as needed to assure that you will be able to properly secure the tank.

Tank Preparation

WATER INLET FITTING - The Hydro-Well III gives you the option of mounting the water inlet fitting on the top of the tank on either the right or left side of the tank. Choose the location on the top right or top left side of the tank that best suits your layout and to install the Float Valve Assembly inside the tank.

Apply Teflon Tape to the threads on both ends of the 1/2" x 4" SS Nipple (NM5825). Attach the 1/2" F-F 90° Elbow (BR296) to one end of the 1/2" x 4" SS nipple.

Reach inside the tank and thread the other end of the nipple into the 1/2" female pipe thread end of the bulkhead fitting on the top of the tank. Tighten the nipple so it will not leak, and turn the nipple so the elbow points toward the back of the tank. (Do not over-tighten nipple. bulkhead fitting can be damaged if over-tightened.)

Apply thread sealant to the male threads on the Float Valve (PBL23025). (Do not attach Float Arm and Float ball until after Valve is installed.)

Thread the Float Valve into the 1/2" F-F 90° Elbow. Tighten the Float Valve so it will not leak, and turn the valve so the outlet port is pointing down.

Attach the Float Arm & Float Ball Assembly to the Float Valve. Adjust Position of Float Arm to shut off flow before water level reaches the Tank Vent/Overflow port on the side of the tank.

Apply thread sealant to the male threads on the 1/2" M-F Elbow (BR286). Thread the elbow into the 1/2" female pipe thread on the bulkhead fitting on the outside of the molded in fitting on top of the tank where you just installed the Float Valve Assembly. (Do not over-tighten elbow. Bulkhead fitting can be damaged if over-tightened. This damage will not be covered under the product warranty)

You can now connect the appropriate inlet fitting to connect to your water supply hose, such as a garden hose fitting or quick connect. (Quick connects or other hose connection fittings are not included with the Hydro-Well III.)

Apply thread sealant to one of the PVC 1/2" Hex Plugs (BR226P). Thread the plug into the unused water inlet port on the other side of the tank.

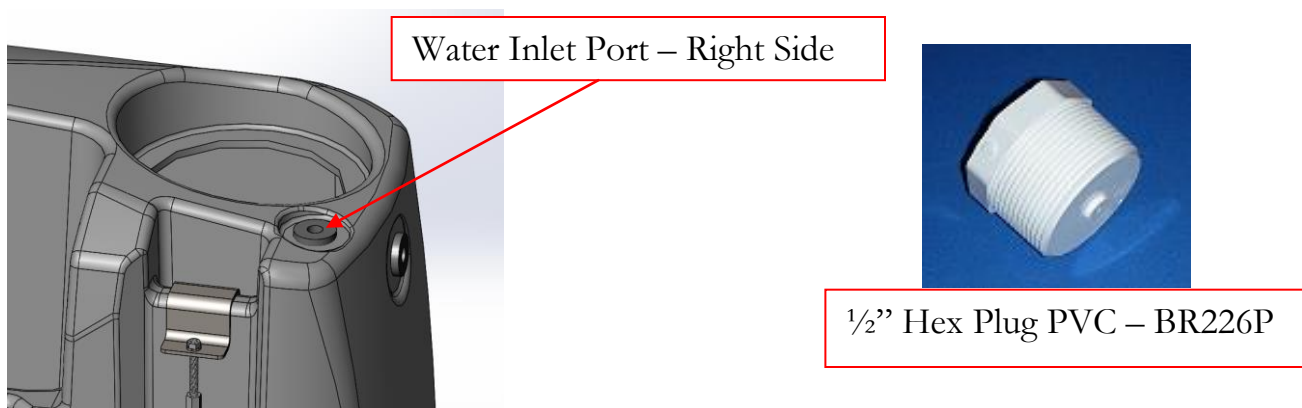

WATER OUTLET FITTING - The Hydro-Well III gives you the option of mounting the water outlet fitting on the bottom back of the tank toward the right or left side of the tank.

Choose the location that best suits your layout and to install the water outlet fittings on the bottom of the tank.

Apply thread sealant to the male threads on the second 1/2" M-F Elbow (BR286). Thread the elbow into the 1/2" bulkhead fitting on the outside of the tank on the bottom port you have selected as your water outlet. Tighten the elbow and align the open end of the elbow in the direction you will be running your water outlet hose. (Do not over-tighten nipple. Bulkhead fitting may be damaged and leak if fittings are over-tightened. This damage will not be covered under the product warranty)

Apply thread sealant to the 1/2" pipe threads on the 3/4" Hose Barb (BR044). Thread the barb into the elbow. Tighten enough so it will not leak, but do not over-tighten.

Apply thread sealant to one of the PVC 1/2" Hex Plugs (BR226P). Thread the plug into the unused water outlet port on the other side of the tank.

If desired another elbow and a ball valve can be installed in the unused water outlet port as a tank drain. It is a good idea to put a male garden hose fitting on the drain to allow you to connect a garden hose when draining the tank. A cap should be put on the outlet side of the ball valve to prevent leaking if the valve is accidentally opened. Drain valve and fittings are not included with the Hydro-Well III.

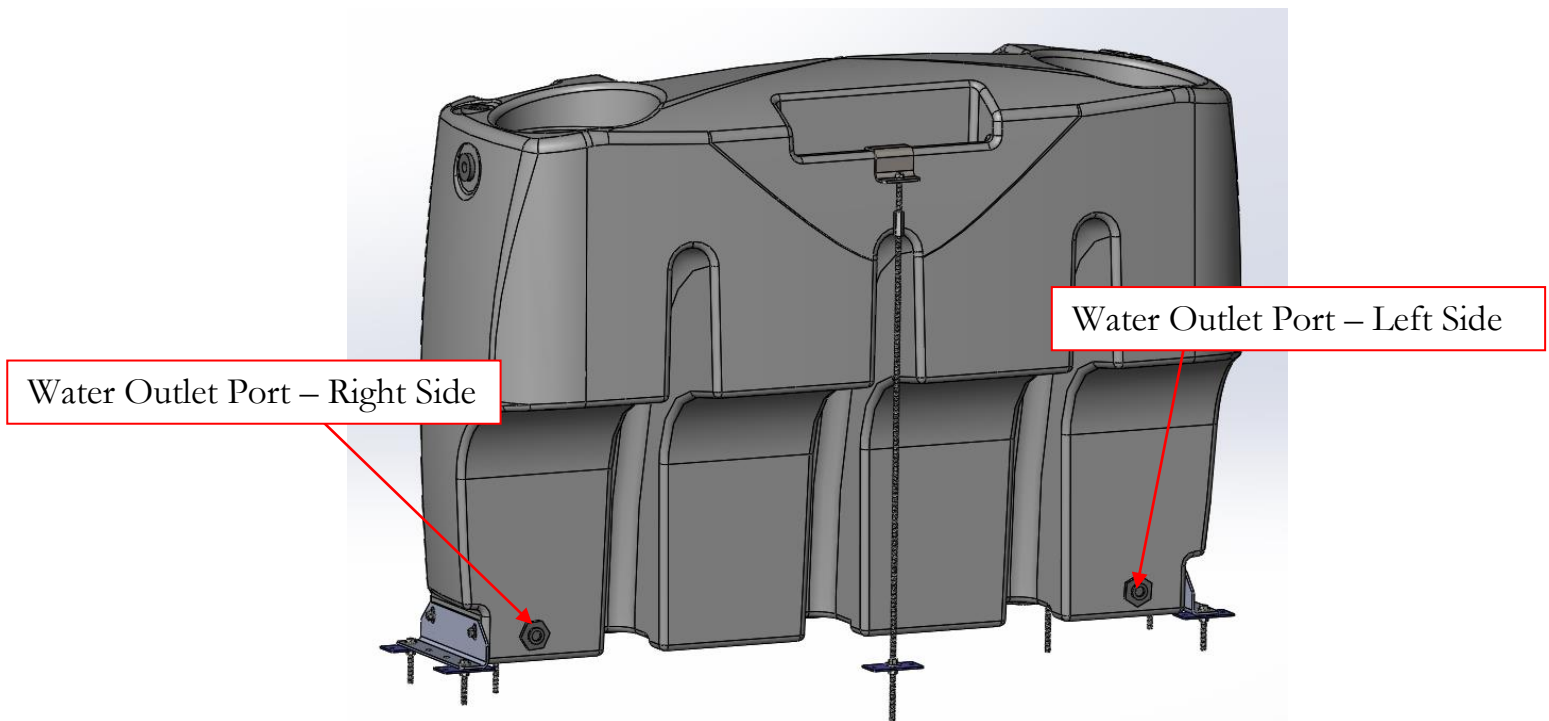

BACK VIEW OF TANK

TANK VENT & OVERFLOW FITTING - The Hydro-Well III gives you the option of mounting the water overflow fitting on the right side, left side or both sides of the tank.

Choose the location that best suits your layout and to install the overflow fittings on the side of the tank. Drill a 1" hole through the flow to allow the 3/4" ID overflow hose to extend through the floor and under the van to prevent the overflow water from draining into the van.

Tank overflow fittings, consisting of one 1/2" M-F Elbow (BR286) and one 3/4" Hose Barb x 1/2" MPT (BR044), are included with the Hydro-Well III.

Tank Vent & Overflow Fittings must be installed to protect tank from damage due to overfilling or over-pressurizing. Failure to install the Tank Vent & Overflow Fittings will void the Hydro-Well III warranty.

Only fill the Hydro-Well III while vehicle is parked on a level surface. Pressure regulator must be used on hose when filling tank.

There are two Overflow Ports one on each side of the tank. The use of one overflow assembly is required. The other Vent/Overflow port can be blocked with the PVC 1/2" Hex Plug (BR226P) included with the Hydro-Well III.

The 3/4" ID hose & hose clamp are not included with the Hydro-Well III.

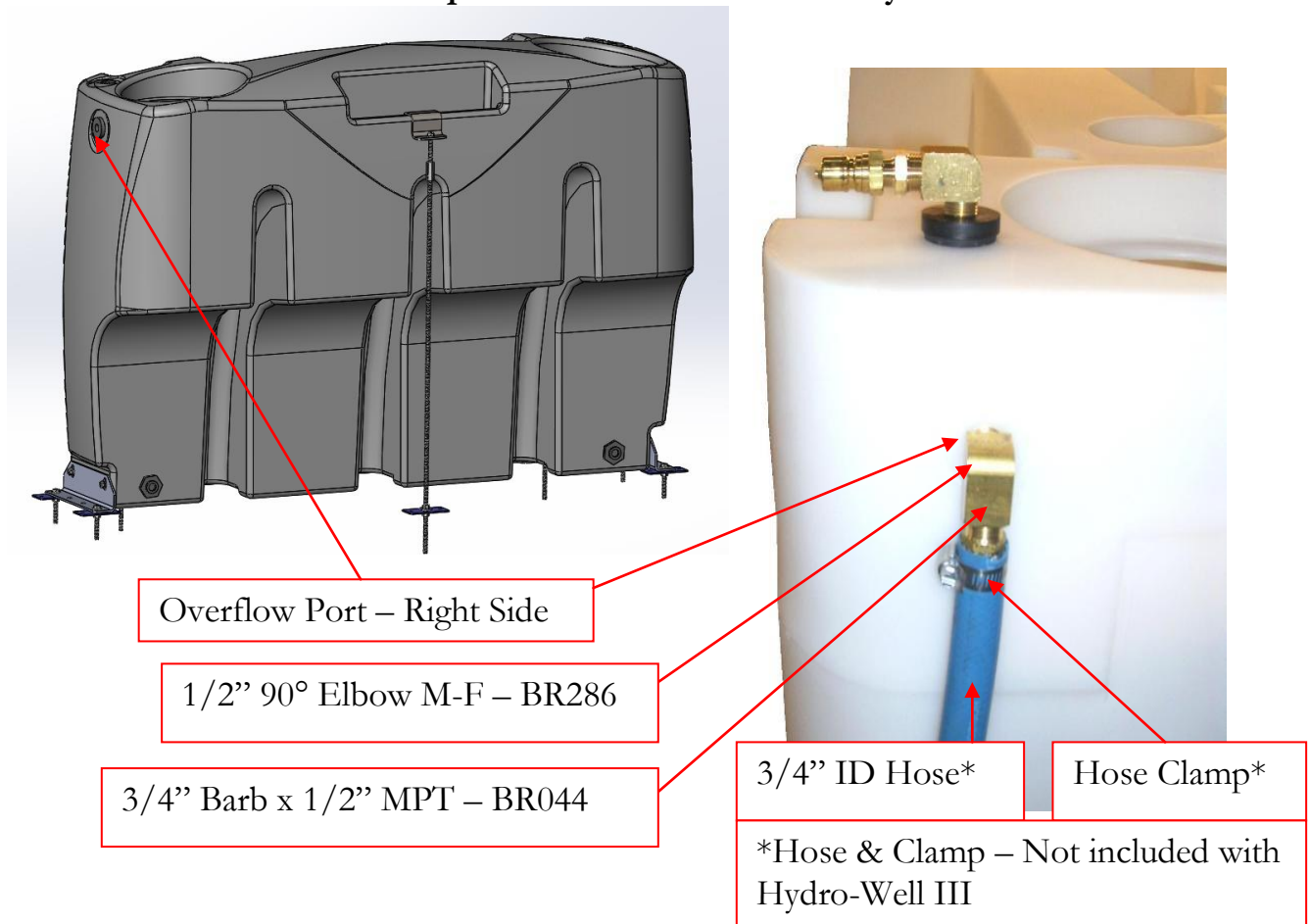

Tank Installation

CAUTION: Before drilling through floor, always check under the vehicle to locate beams and vehicle components such as the gas tank, fuel lines, wiring harnesses, heat shields, spare tire, etc. Position the Hydro-Well III so all required holes can be drilled through floor without damaging vehicle components and bolts are positioned with room to attach mounting plates, washers and nuts for safe and secure mounting.

Keep proper clearances from moving parts or hot surfaces. Leave access room for servicing other equipment as required.

To ease assembly it is recommended that you connect outlet water fittings as outlined in previous section before mounting tank.

1. Position the tank and mark the location of the holes to be drilled.

For proper installation two bolts must be used to secure each of the two floor brackets to the floor (One bracket on each end of the tank). All three hold-down rods (Two on the front & one on the back) must also be installed. The floor brackets have four holes available to allow some flexibility in bolt placement. For the most stable mounting use the two outside holes. The farther apart the bolts are, the more stable the bracket will be. There is also a little flexibility in the placement on the hold-down rods. The hold-down brackets can be slid from side to side to move the location as needed to avoid obstructions under the van. Keep hold-down rods perpendicular to van floor.

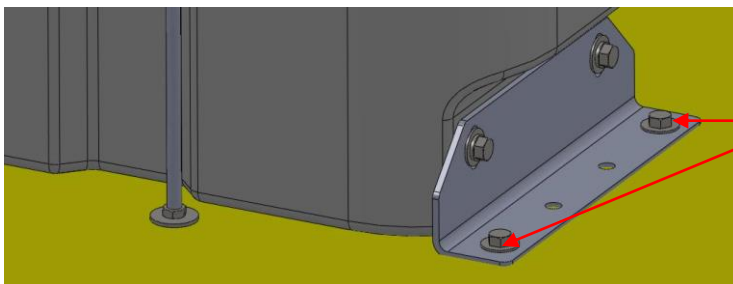

For the most stable mount, use the two outside bolt holes

Move bolts to other holes only if needed to avoid obstacles under van floor.

For the most stable mounting keep the hold-down brackets centered in the original mounting areas and keep the hold-down rods perpendicular to the floor. Move hold-down rod assemblies only as needed to avoid obstacles under van floor.

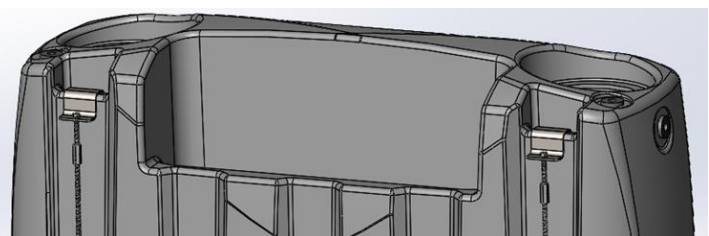
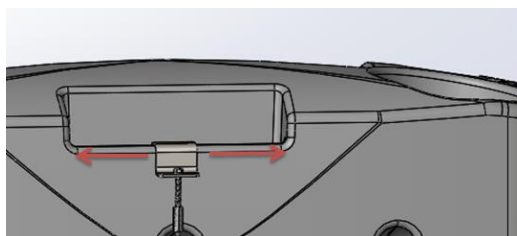

2. Once you have checked for obstacles under the vehicle & determined the correct hole positions, drill 3/8" holes for each bolt & hold down rod. Use a drill bit depth stop or shield if needed to prevent going through too far and damaging vehicle components.
3. Thread 3/8" jam nut (6) onto hold-down rod (5) to proper depth to go through van floor or wheel well; about 1-3 inches.
4. Thread 3/8" coupler (4) onto the top of the hold-down rod. Place 3/8" tap bolt (3) through hole in hold down bracket (2) and thread bolt into coupler.
5. Place 3/8" fender washer (7) on rod & push rod through hole. Hook the bracket over the edge of the tank and tighten the tap bolt and move the jam nut as needed to adjust the height of the hold-down assembly. Leave extra threads open between the tap bolt and coupler and coupler and rod for later adjustments if needed. **Adjust rod height to secure the bracket to the tank such the bracket and tank will not move, but not too tight. Over-tightening the hold down rod may damage the tank.**

(If you had to move front hold down over to shelf area to avoid obstacles you will need to shorten hold-down rod.)

6. Under the van, place back-up plate (13) on rod and secure to floor using the 3/8" lock washer (10) and 3/8" nut (14) tightened against jam nut on top of floor. Re-adjust the 3/8" coupler as needed to maintain proper rod tension.

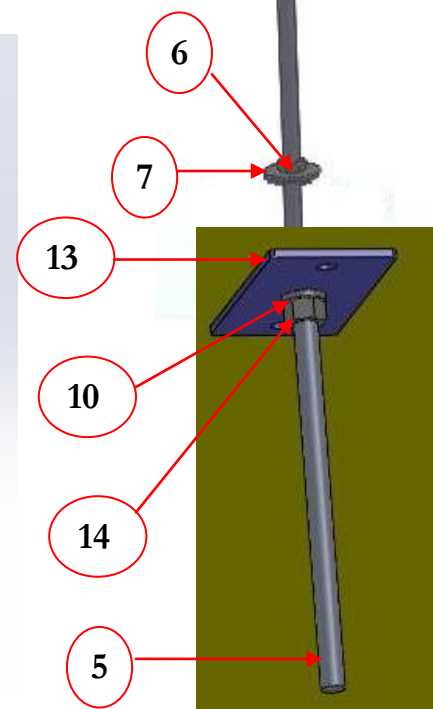
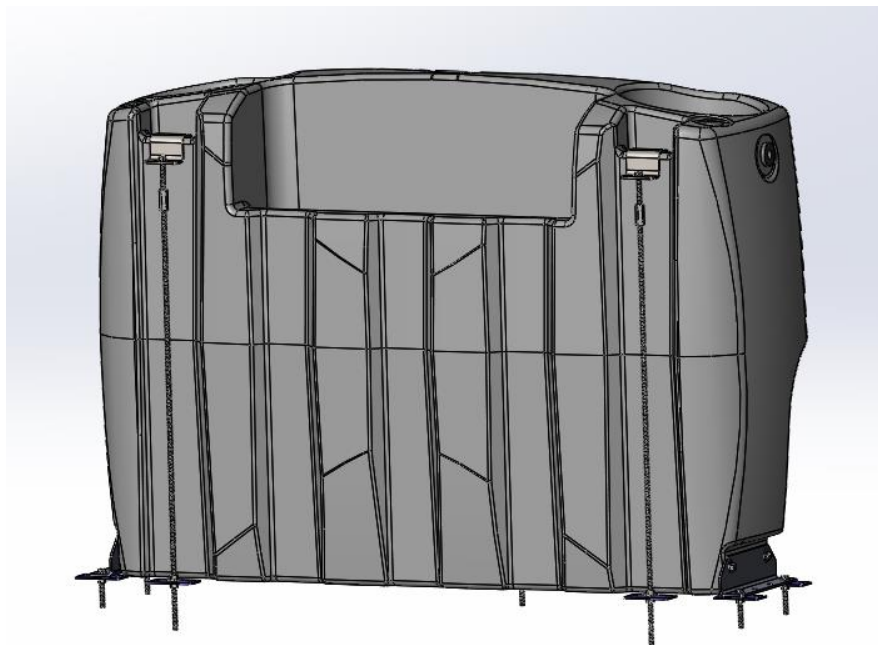

- Place a 3/8" flat washer (11) on each of the four 3/8" tap bolts (3) and insert the bolts through holes in floor bracket (8). Two bolts & washers on each floor bracket on each end of the tank.
- Under the van, place back-up plate (13) on each bolt and secure to floor using the 3/8" lock washer (10) and 3/8" nut (14).

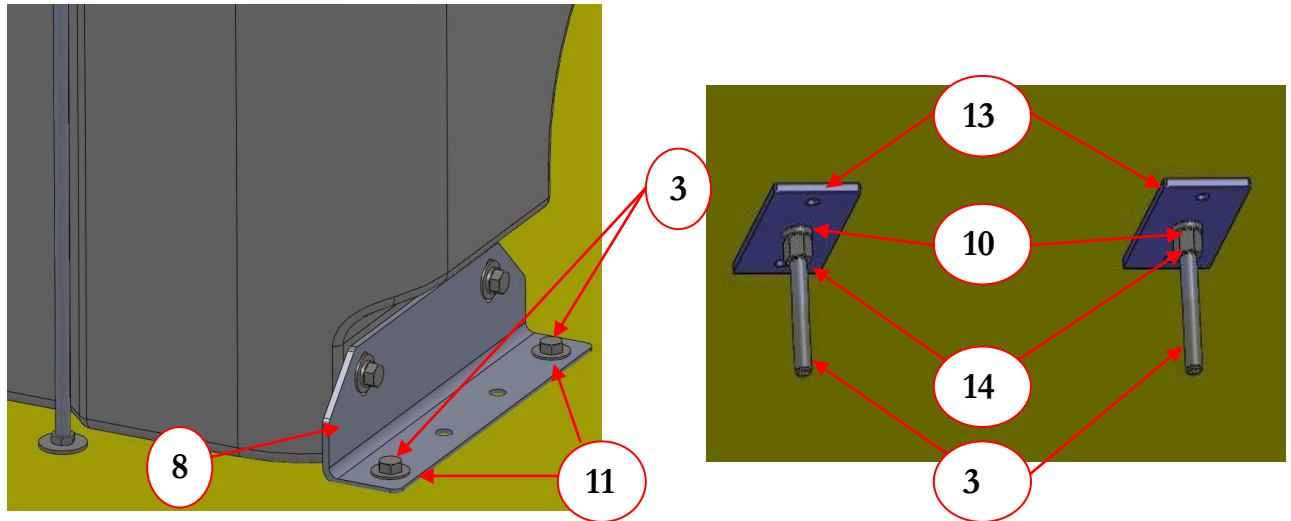

- Connect inlet water fittings, water supply pump, overflow fittings, outlet water fittings and hoses as needed.



AP36



AP38

- Fill tank 1/3 full of water and check hold down rods and re-tighten as needed. Check for leaks drain tank and reseal fittings as needed.

Optional Parts & Accessories

Inlet Parts:



PAF01 3/8" MALE QUICK CONNECT BRASS

PAF02 3/8" FEMALE QUICK CONNECT BRASS

BR136 REDUCING HEX NIPPLE 1/2" X 3/8" BRASS

BR327 ADAPTER 3/4" FGH X 1/2" FPT BRASS

BR076 NIPPLE 1/2" HEX BRASS

Outlet Parts:



AH66 3/4" ID WATER HOSE – SOLD PER FOOT

PH09 – HOSE CLAMP

AP36 – 45PSI 4.5 GPM DEMAND PUMP PRESSURE SYSTEM

AP38 – 35PSI 3.7 GPM PUMP W/ Variable Speed Demand Control

PF01740-000 – INLINE FILTER WITH 3/4" HOSE BARBS

PF20381-010 – ELBOW 3/4" BARB FOR FLOJET QUAD PUMPS

PF20381-006 – STRAIGHT 3/4" BARB FOR FLOJET QUAD PUMPS

AH60 – 1/2" ID WATER HOSE – SOLD PER FOOT

PAF01 3/8" MALE QUICK CONNECT BRASS

PAF02 3/8" FEMALE QUICK CONNECT BRASS

BR030 – 1/2" HOSE BAR X 3/8" MPT BRASS

BR284 – ELBOW 90 DEG 3/8" M-F STREET BRASS

Drain Parts:



BR286 ELBOW 90 DEG 1/2" M-F STREET BRASS

BR030 – 1/2" HOSE BAR X 3/8" MPT BRASS

BR136 REDUCING HEX NIPPLE 1/2" X 3/8" BRASS

AH51 BALL VALVE 3/8" FPT

BR320 ADAPTER 3/4" MGH X 3/8" MPT BRASS

BR325 GARDEN HOSE CAP BRASS

BR600 GASKET GARDEN HOSE CAP

| KEY | Part # | Hydro-Well III Parts Description | QTY |
|------------|---------------|--|------------|
| 1 | NM5803 | TANK HYDRO-WELL III RAW (Includes - NM4267 Bulkhead fittings) | 1 |
| 2 | NM5802 | BRACKET TIE DOWN REAR | 3 |
| 3 | NM5812 | BOLT TAP 3/8-16 x 3" ZINC PLTD | 7 |
| 4 | NM5808 | NUT COUPLING 3/8-16 GRADE 2 ZINC PLTD | 3 |
| 5 | NM5806 | ROD THREADED 3/8-16 x 36" ZINC PLTD | 3 |
| 6 | NM5816 | NUT JAM 3/8-16 HEX ZINC PLTD | 3 |
| 7 | NM5810 | WASHER FLAT FENDER 3/8" ZINC PLTD | 3 |
| 8 | NM5804 | BRACKET FLOOR MOUNTING | 2 |
| 9 | NM5814 | BOLT 3/8-16 x .75" ZINC PLTD | 4 |
| 10 | NM4368 | WASHER LOCK 3/8" SPLIT ZINC PLTD | 14 |
| 11 | PA189 | WASHER 3/8" ZINC PLTD | 8 |
| 13 | NM5818 | BACK-UP PLATE – BRACKET HYDRO SHELF | 7 |
| 14 | NM4366 | NUT 3/8-16 HEX ZINC PLTD | 7 |
| 17 | 1650-5695 | LID ASSEMBLY 8 INCH W/ DECK | 2 |
| NS | 1663-5397 | GASKET – FOR 8" LID DECK | 2 |
| 18 | PA187 | SCREW #10 X 5/8" PPHD SS | 12 |
| 19 | PBL23025 | FLOAT VALVE | 1 |
| 20 | NM5825 | NIPPLE 1/2" X 4" SS | 1 |
| 21 | BR226P | PLUG 1/2" HEX PVC | 3 |
| 22 | BR044 | BARB 3/4" X 1/2" MPT | 2 |
| 23 | BR286 | ELBOW 90 DEG 1/2" STREET M-F BRASS | 3 |
| 24 | NM4267 | BULKHEAD FITTING 1/2" FPT PVC | 4 |
| 25 | BR296 | ELBOW 90 DEG 1/2" F-F BRASS | 1 |
| 26 | NM5827 | FLOAT BALL | 1 |
| 27 | NM5826 | THREAED ROD 1/4-20 X 1-3/4" SS | 1 |
| 28 | NM4003 | NUT 1/4-20 HEX SS | 2 |

Hydro-Well III Parts

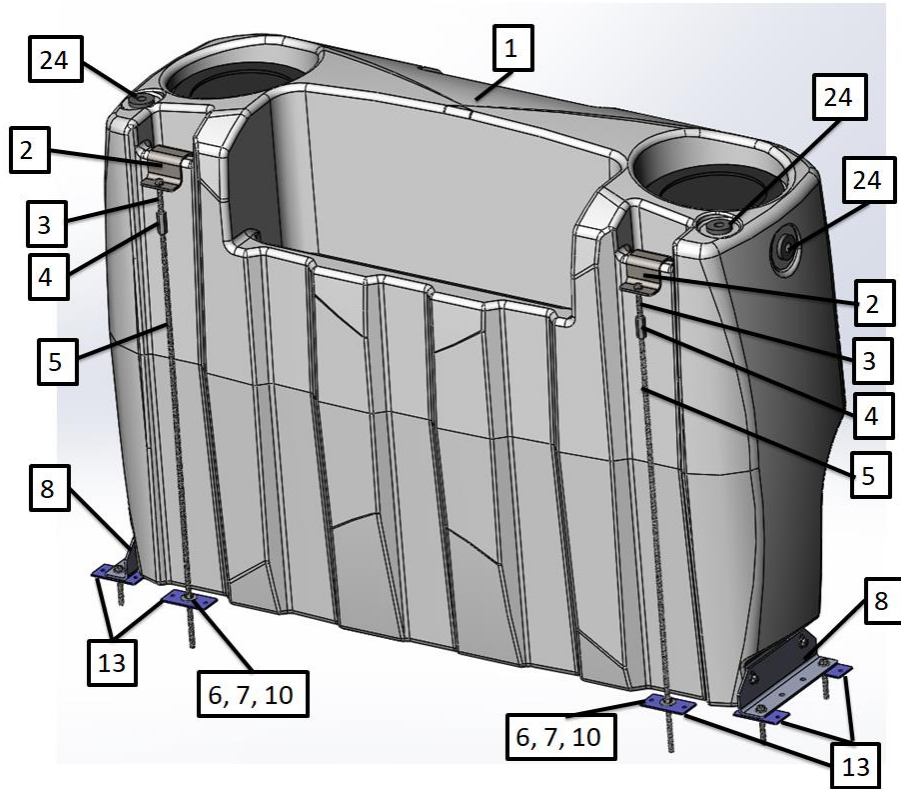
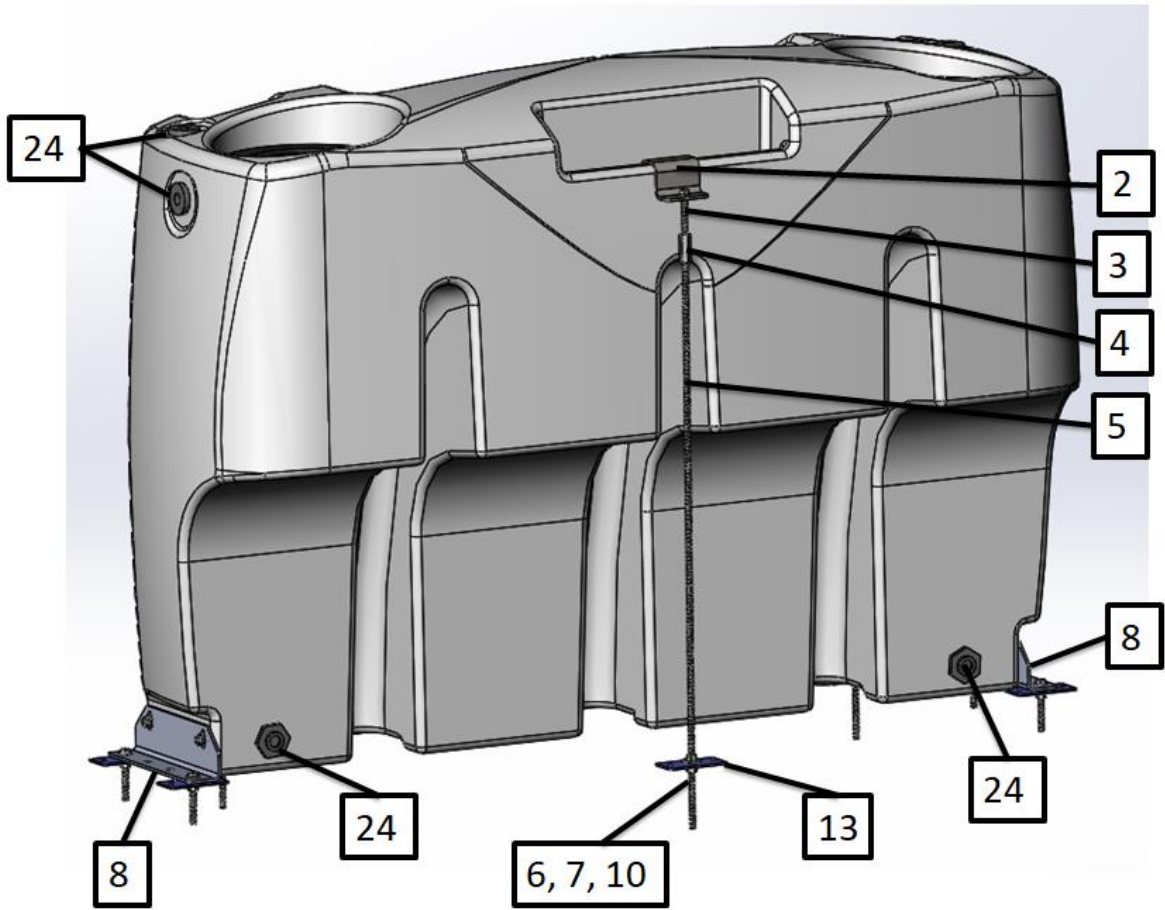

Hydro-Well III Parts

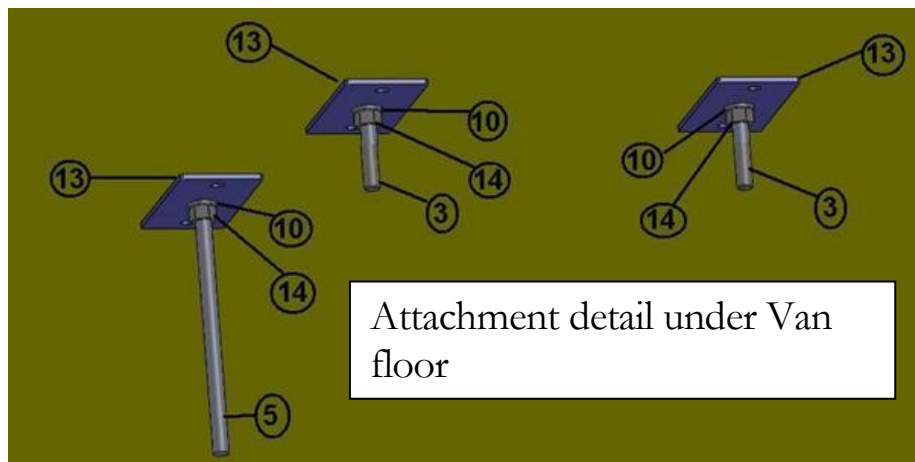
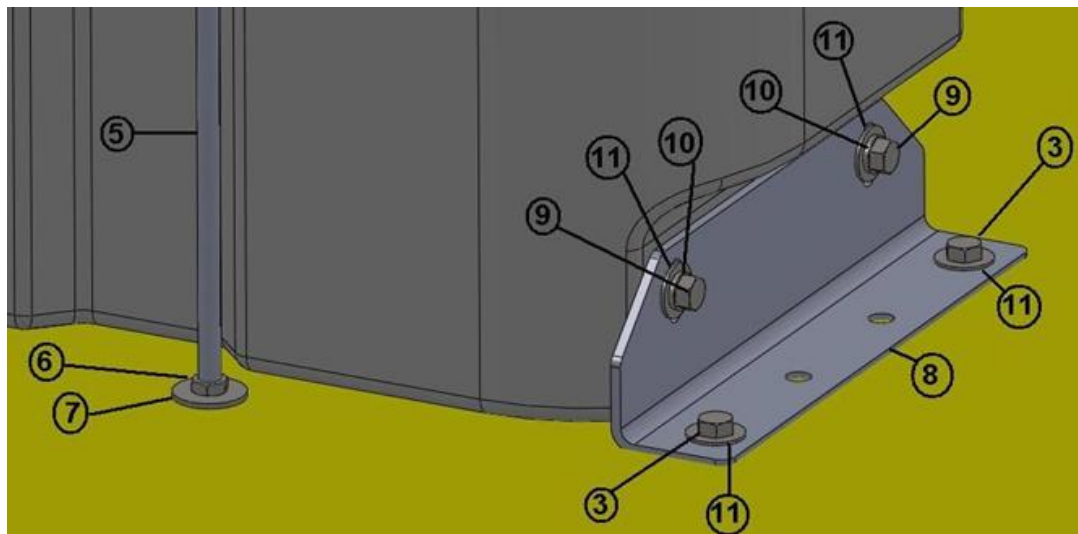
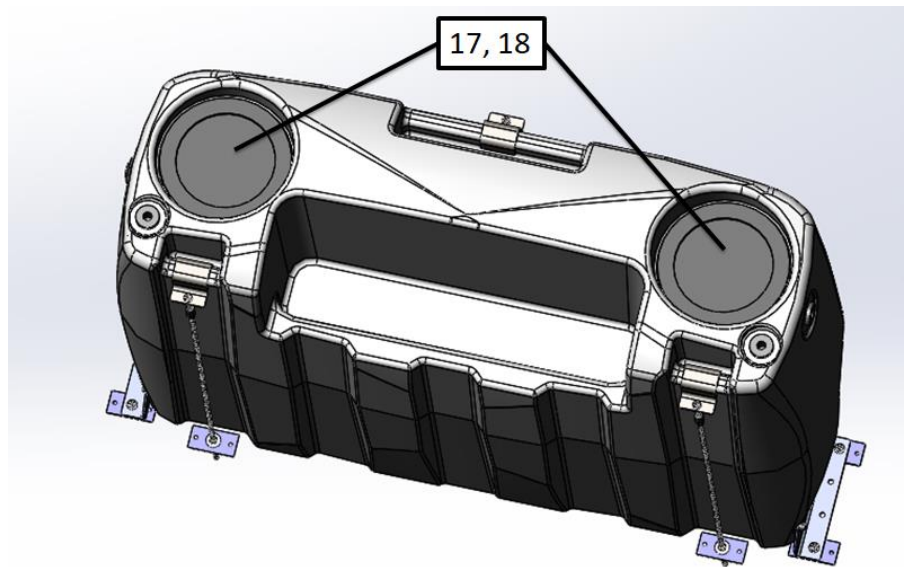

Hydro-Well III Parts

*Indicates item is not included with Hydro-Well III

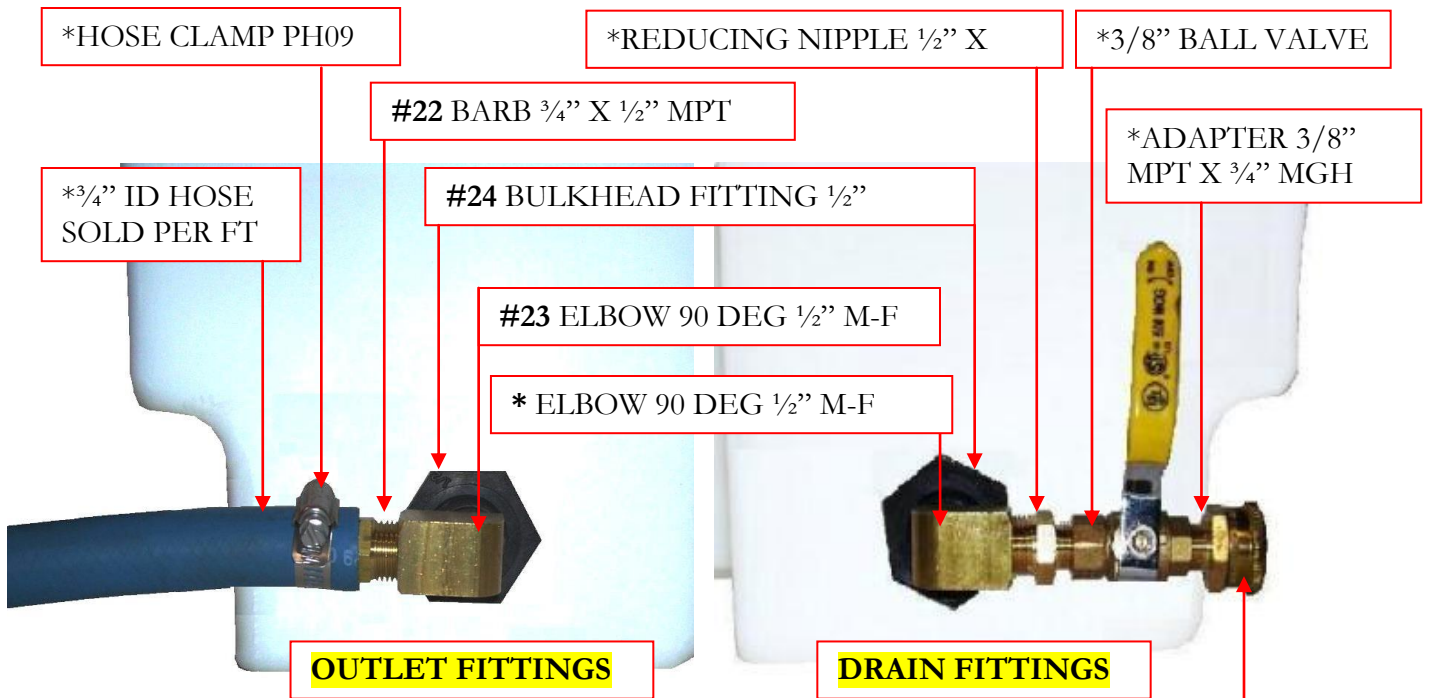
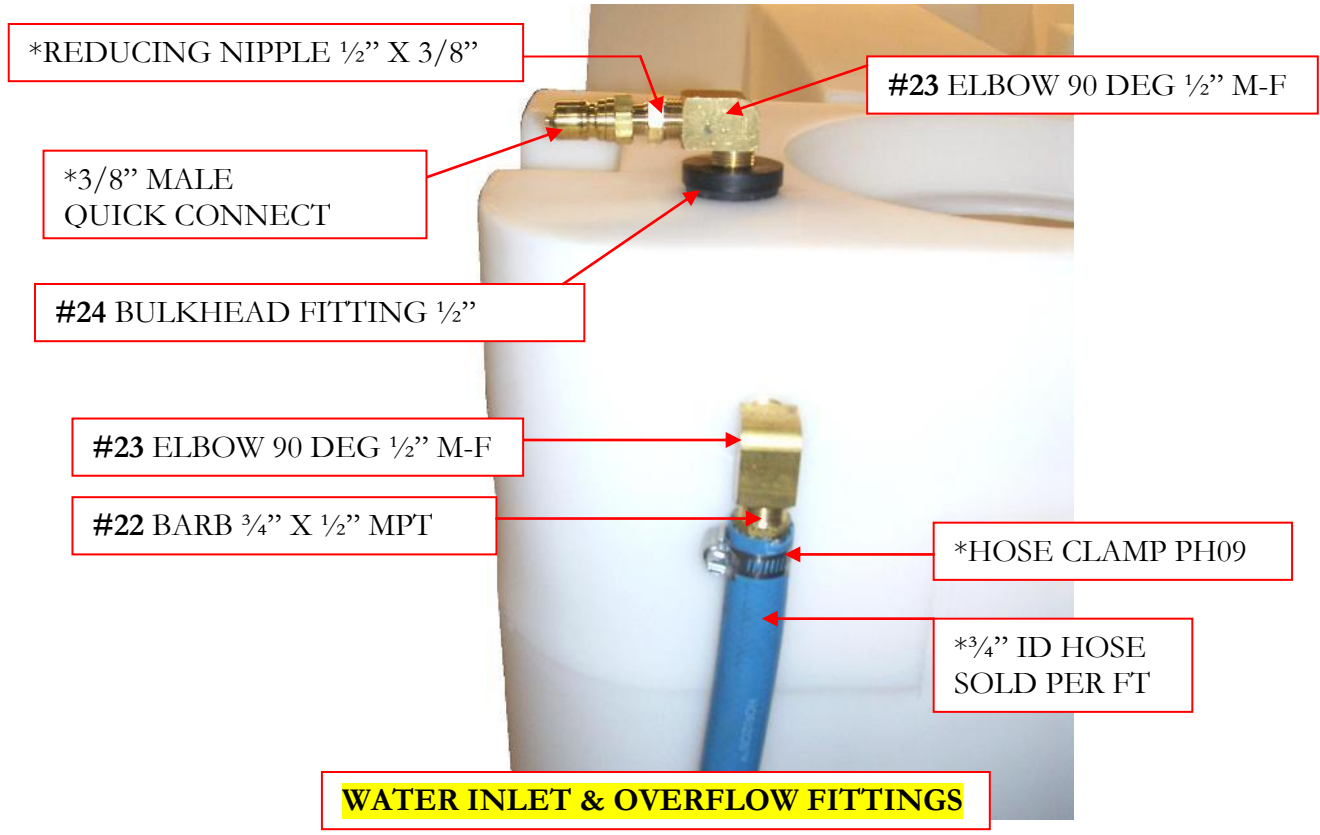

*Indicates item is not included with Hydro-Well III

*GARDEN HOSE CAP & *WASHER

Hydro-Well III Parts

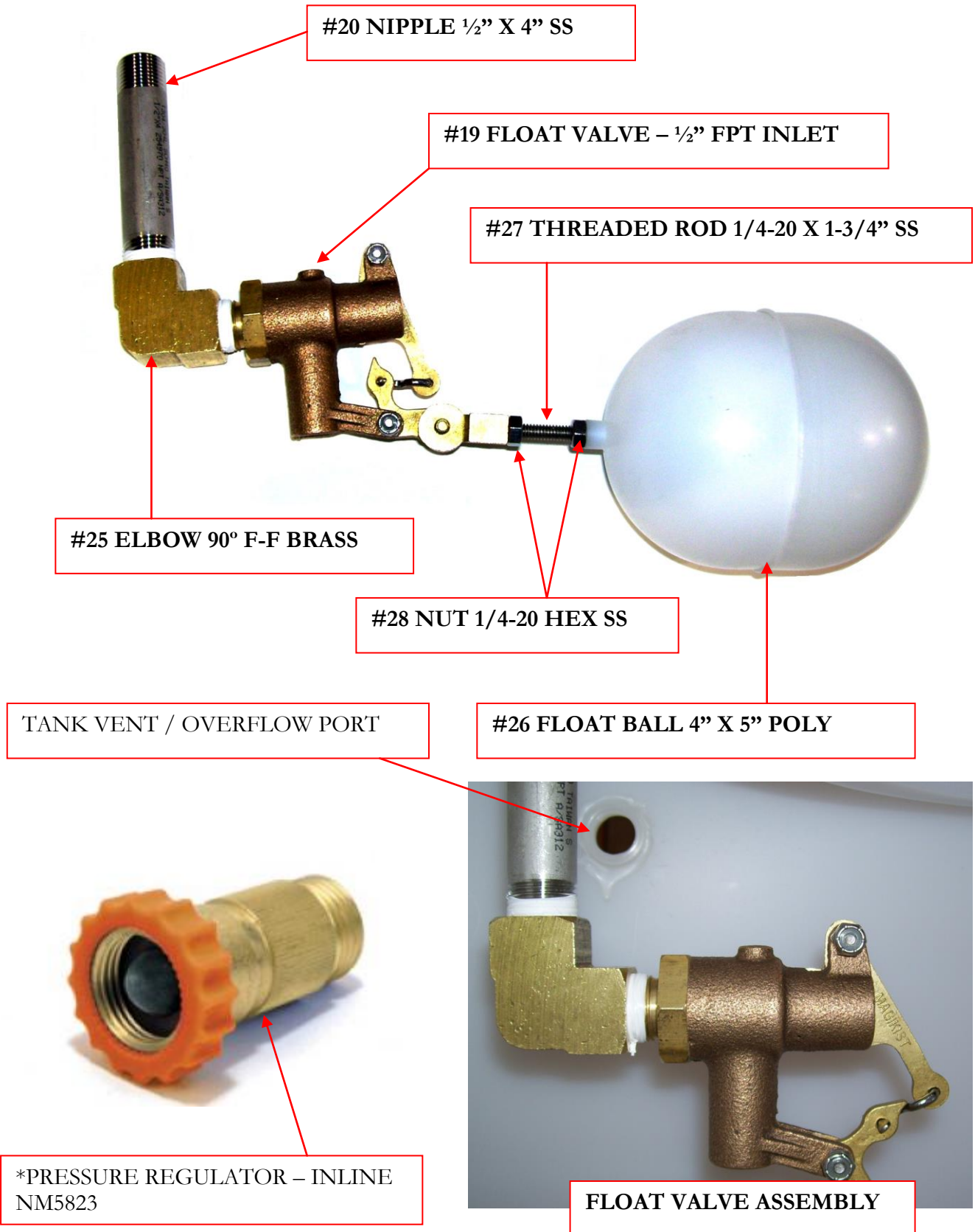

LIMITED WARRANTY

Your Hydro-Well III is designed to give you years of reliable service. If a problem should arise contact your distributor or Hydro Force for assistance.

Hydro Force warrants the Hydro-Well III to be free from defects in material or workmanship for three years / 36 months from the date of purchase.

During the warranty period, Hydro Force will, at its option repair or replace the components which prove to be defective. Any costs for transportation or related service labor are not covered in this warranty. Replacement parts are warranted only for the remainder of the original warranty period.

This warranty shall not apply to defects resulting from improper installation, unapproved modification, abuse, neglect, damage caused by freezing water or heat sources, such as space heaters, water heaters & truck mount engines.

To obtain warranty service for the Hydro-Well III, contact your distributor or Hydro Force. If the tank must be returned to Hydro Force or an authorized service center, the purchaser shall prepay shipping charges for products returned for warranty service. No returned items will be accepted by Hydro Force without prior authorization. All returns must have a return authorization number, issued by Hydro Force, clearly marked on the exterior of the package.

Hydro Force makes no other warranty either expressed or implied with respect to this product.

The remedies provided herein are the purchaser's sole and exclusive remedies. In no event shall Hydro Force be liable for any direct, indirect, special, incidental or consequential damages.

This warranty gives you specific legal rights. You may also have other rights which vary from jurisdiction to jurisdiction.